

Technical Data Sheet

Cup Stock / Hi Bulk

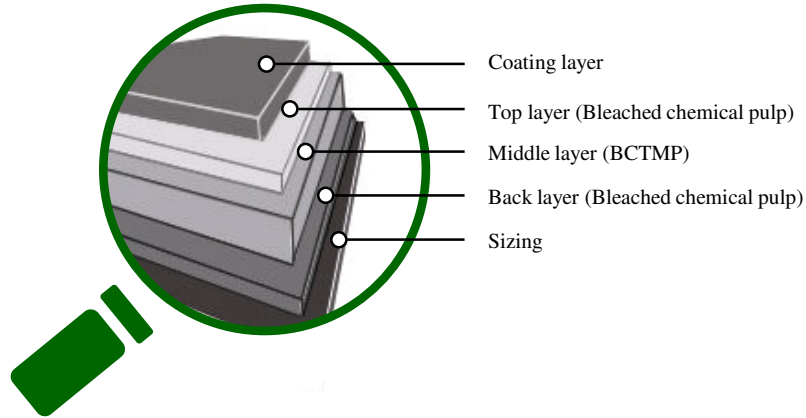

Issued on: 06.02.2024

Property	Unit	Tolerance	Value											Standard
Grammage	g/m ²	±3%	180	190	210	220	230	240	250	260	280	300	320	ISO536
Thickness	µm	±3%	270	285	315	330	345	360	375	390	420	450	480	ISO534
Moisture	%	±1.5	7.5	7.5	7.5	7.5	7.5	7.5	7.5	7.5	7.5	7.5	7.5	ISO287
Stiffness Taber 15° MD	mN.m	≥	3.0	4.5	5.5	6.5	8.0	9.0	9.5	12.5	15.0	16.0	19.0	ISO2493
Stiffness Taber 15° CD	mN.m	≥	1.5	2.0	2.8	3.0	3.2	3.5	4.0	5.0	7.0	8.0	9.0	ISO2493
Top Brightness	%	≥	80.0	80.0	80.0	80.0	80.0	80.0	80.0	80.0	80.0	80.0	80.0	ISO2470
Top Surface Roughness PPS10	µm	≤	1.5	1.5	1.5	1.5	1.5	1.5	1.5	1.5	1.5	1.5	1.5	ISO8791
Top Surface Strength	m/s	≥	1.3	1.3	1.3	1.3	1.3	1.3	1.3	1.3	1.3	1.3	1.3	ISO3783
Scott Bond	J/m ²	≥	120	120	120	120	120	120	120	120	120	120	120	TAPPI T569
Edge Wicking	kg/m ²	≤	2.0	2.0	2.0	2.0	2.0	2.0	2.0	2.0	2.0	2.0	2.0	-

All properties are according to Asia Symbol Rugao Mill measurements.

Test climate 23°C/50% RH (According to ISO 187).

In order to verify, reel/pallet average shall be based on 5 single measurements randomly sampled within the reel/pallet.

These averages will be for at least 19 of 20 reels/pallets within the specification limits.

This product is OBA free.